

Volute Pumps

SIHI *SuperNova*



ZLIC 040160 . . . 150200

TECHNICAL DATA

Output:	max. 280 m ³ /h
Head:	max. 60 m
Speed:	max. 3600 rpm
Material:	grey cast iron: 0B, 0C stainless steel: 4B
Temperature:	mat. design: 0B, 0C, 4B max. 120 °C
Casing pressure:	PN 16 / PN 10 ¹⁾
Shaft seal:	standard mechanical seal
Flange connections:	DIN 2501 PN 16
Sense of rotation:	clockwise, when looking at the pump from the drive end

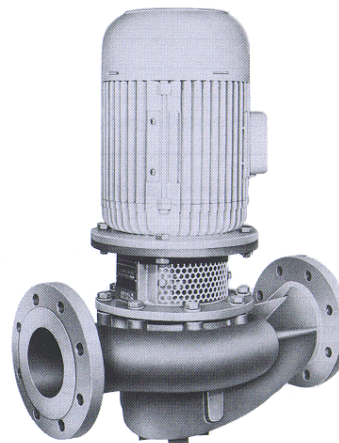

APPLICATION

Volute pumps of the series ZLIC in inline design have been constructed as space saving and easy to install pumping units with standard motor. The pumps are used when clear resp. turbid liquids without any solid particles have to be pumped without problem.

The combination of:

- performance and connection size according to DIN 24255 /EN 733 and additional size DN 25
- construction type: INLINE design with standard motor
- material: grey cast iron, stainless steel
- casing: inline or volute casing (see list ZLK)

was leading to widely spread application fields like

- steel, machine and automobile construction
- food and semi-luxuries industry
- chemical and petrochemical industry
- pharmaceutical industry
- lacquer industry
- plastics and rubber industry
- iron and non-ferrous metal industry
- paper and pulp-industry
- textile industry

DESIGN

Single-stage resp. two-stage pumping units in compact design with nominal performances according to DIN 24255 / EN 733 as well as additional size DN 25, where suction and discharge branch are arranged opposite to direct installment into the pipework.

There is no common shaft for motor and pump. The motors used are of the standard type listed.

Thanks to the process design it is possible to withdraw the whole insert unit without removing the casing of the pump from pipework.

By means of the unit construction system of the additional size DN 25 the single-stage and the two-stage design have the same dimensions. The performance of the pump is optimally adapted to the service point by mounting and dismounting of a stage.

The individual shafts of the unit connected by a plug-in coupling facilitate the dismantling or the replacement of the motor without affecting the pump.

The programme comprises. 15 pump sizes at present.

¹⁾ For size 150200 only

CONSTRUCTION

Casing pressure:

Material design	
4B	max. 16 bar from -40 °C to 120 °C
0B, 0C	max. 16 bar from -30 °C to 120 °C

Please note:

Technical rules and safety regulations.

Casing pressure = inlet pressure plus delivery head + zero flow

Flanges location:

Suction and discharge flange radially arranged opposite to each other.

Flanges:

The flanges correspond to DIN 2533 PN 16. Flange drilled ANSI 150 lbs. on request.

Hydraulic:

First hydraulic. Designation of this construction type: A·

Second hydraulic. Designation of this construction type: B·

Bearing:

Two grease-lubricated antifriction bearings according to DIN 625 in the motor, one antifriction bearing grease-lubricated for service-life according to DIN 625 arranged in the bearing bracket. Designation of this construction type: ·K, ·V

Sense of rotation:

Clockwise when looking at the pump from the drive end.

Shaft sealing:

The shaft sealing is a single mechanical seal, flushed from internal source, uncooled and unbalanced.

Designation AAE: cast chrome / carbon, O-rings Perbunan
temperature range: -40 °C to 120 °C

Designation BH3: SiC / carbon, elastomer EP
temperature range: -20 °C to 120 °C

Designation BHS: SiC / SiC, elastomer Viton
temperature range: -20 °C to 120 °C

Material design

Item	Components	Material						Execution		
		EN material-number	EN material-denomination	DIN material-number	DIN material-denomination	US denomination		0B	0C	4B
						ASTM Standard	AISI			
10.10	Volute casing	EN-JL 1040	EN-GJL 250	0.6025	GG 25	A 278 Class 30		X	X	
16.10	Casing cover	1.4408	GX5CrNiMo19-11-2	1.4408	GX6CrNiMo18 10	A 351 CF8M	316			X
34.00	Bearing bracket	EN-JL 1040	EN-GJL 250	0.6025	GG 25	A 278 Class 30		X	X	X
21.00	Shaft	1.4021	X20 Cr13	1.4021	X20 Cr13	A 276 Type 420	420	X	X	
		1.4401	X5CrNiMo18 10	1.4401	X5CrNiMo18 10	A 167 Gr316	316			X
23.00	Impeller	EN-JL 1040	EN-GJL 250	0.6025	GG 25	A 278 Class 30		X		
		2.1050	CC480K	2.1050	G-CuSn10	B 427 C91600			X	
		1.4408	GX5CrNiMo19-11-2	1.4408	GX6CrNiMo18 10	A 351 CF8M	316			X
43.30	Shaft seal	X22CrNi17 / Carbon - Perbunan						X	X	
	Mechanical seal ¹⁾	SiC / SiC - Viton or SiC / carbon - EP						X	X	X

¹⁾ O-rings of PTFE upon request;

Casing seal:

Material design 0B, 0C:

The casing is sealed by a flat gasket of EWP 210. Designation of this construction type: 2

Material design 4B:

The casing is sealed by a flat gasket of PTFE. Designation of this construction type: 4

Motor power:

Using commercial electric motors, type of construction IM B5 resp. IM V 1

To determine the drive power we recommend the following safety margin:

up to 4 kW: 25 %

4 up to 7,5 kW: 20 %

7,5 up to 37 kW: 15 %

Please note: the max. motor power allowed for some construction sizes as shown in the individual characteristic curves.

The following speeds are to be observed:

Max. speed rpm	Size	Max. speed rpm	Size
3600	040160	3000	040200
	050160		050200
	065160		065200
	080160		080200 ²⁾
	100160 ²⁾		100200
			150200

The max. speeds results from the admissible shaft load and from the permitted peripheral speed of the impellers.

²⁾ in material design 4B max. speed 3000 rpm

Positioning

ZLIC pumps can be mounted either horizontally or vertically into the pipe system with sufficient carrying capacity as follows, taking the drive power into consideration:

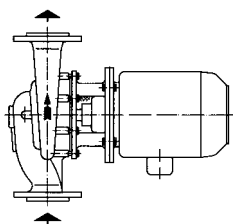

Horizontal installation up to 7,5 kW

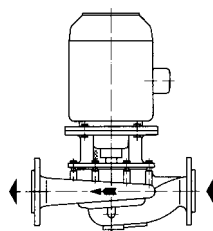

Vertical installation up to 7,5 kW possible, from 11 kW on necessity.

The pump unit can be additionally supported for that. For this particular purpose a threaded bore hole is provided in the pump casing (see dimension table).

Please note

The installation of the motor below the pump is not allowed because of operation safety reasons.

The installation of compensators is not necessary. **Saving of costs!**

General comments

For units in compact design with the same installation set consisting of bearing bracket with bearing, stub shaft and mechanical seal, casing cover, impeller and impeller fastener, please refer to our series **ZLKD**. Technical documentation about these programmes will be readily supplied on request.

Sectional drawing and nomenclature

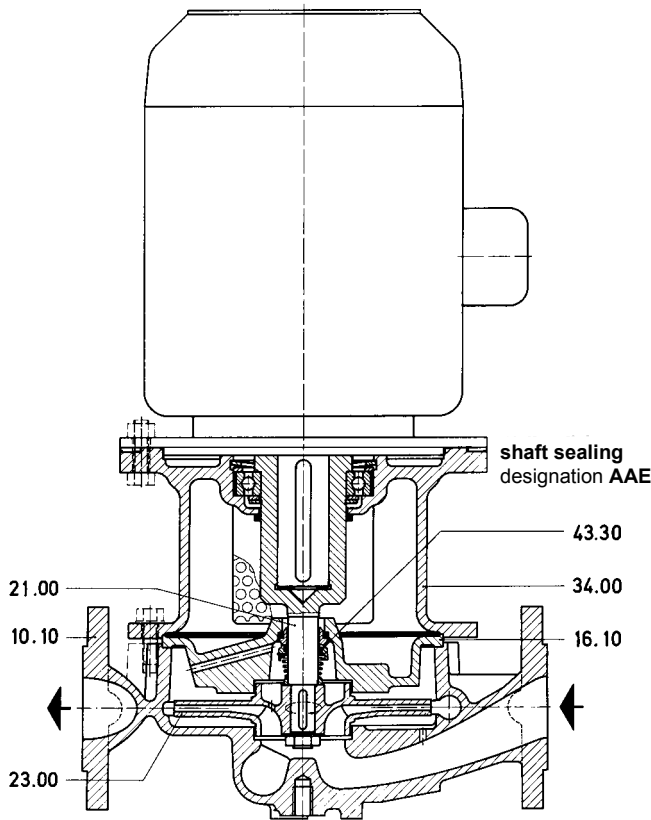

shaft sealing
 designation **BH3**
BHS

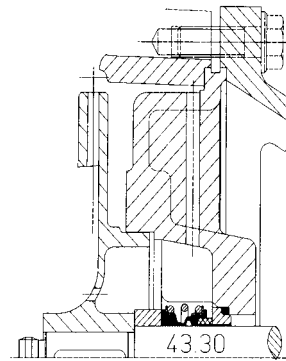

10.10	volute casing	21.00	shaft
16.10	casing cover	34.00	bearing bracket
43.30	mechanical seal	23.00	impeller

Standard set of components / bearing bracket - plug coupling / standard motor* / space requirement

By supplementing the standard set of components consisting of pump casing, casing cover, impeller and mechanical seal by a special bearing bracket (DBP) results an inline pumps which is easy to combine. The bearing bracket removes the standard motor from the load of hydraulic forces and allows suitable motor combinations at the complete mounted pumping unit.

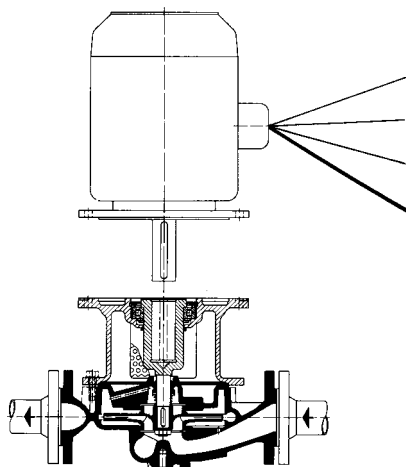

motor combinations

- + type IM B 5 or IM V 1
- + type of enclosure IP 54 to eII (Ex)
- + speed 50 and 60 Hz
- = motor at your choice

- + shaft sealed pumping unit
- = readiness for operation

* shaft end key to DIN 748 part 3 to DIN 6885 sheet 1

If necessary the motor can be changed in the unit without draining, the pipework. The pump unit remains as „**shaft tight armature**“ in the pipe work and so the readiness for operation is increased.

Performance graph

n = 1450 rpm

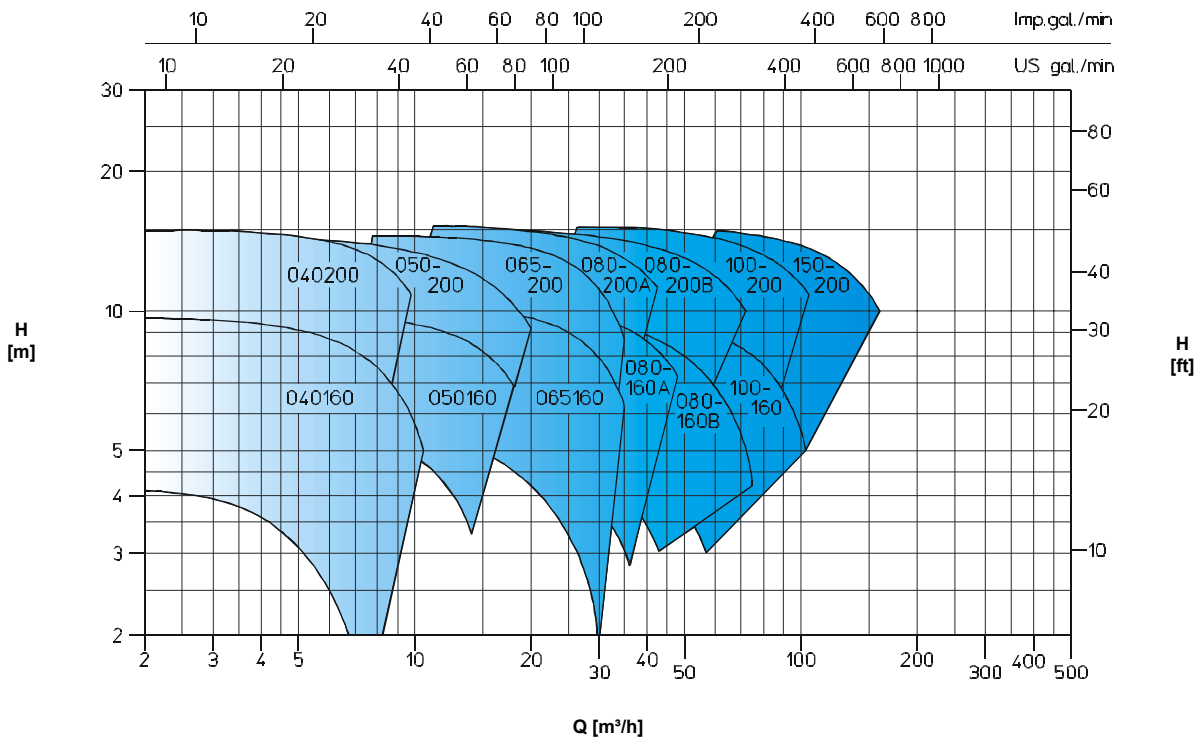

n = 2900 rpm

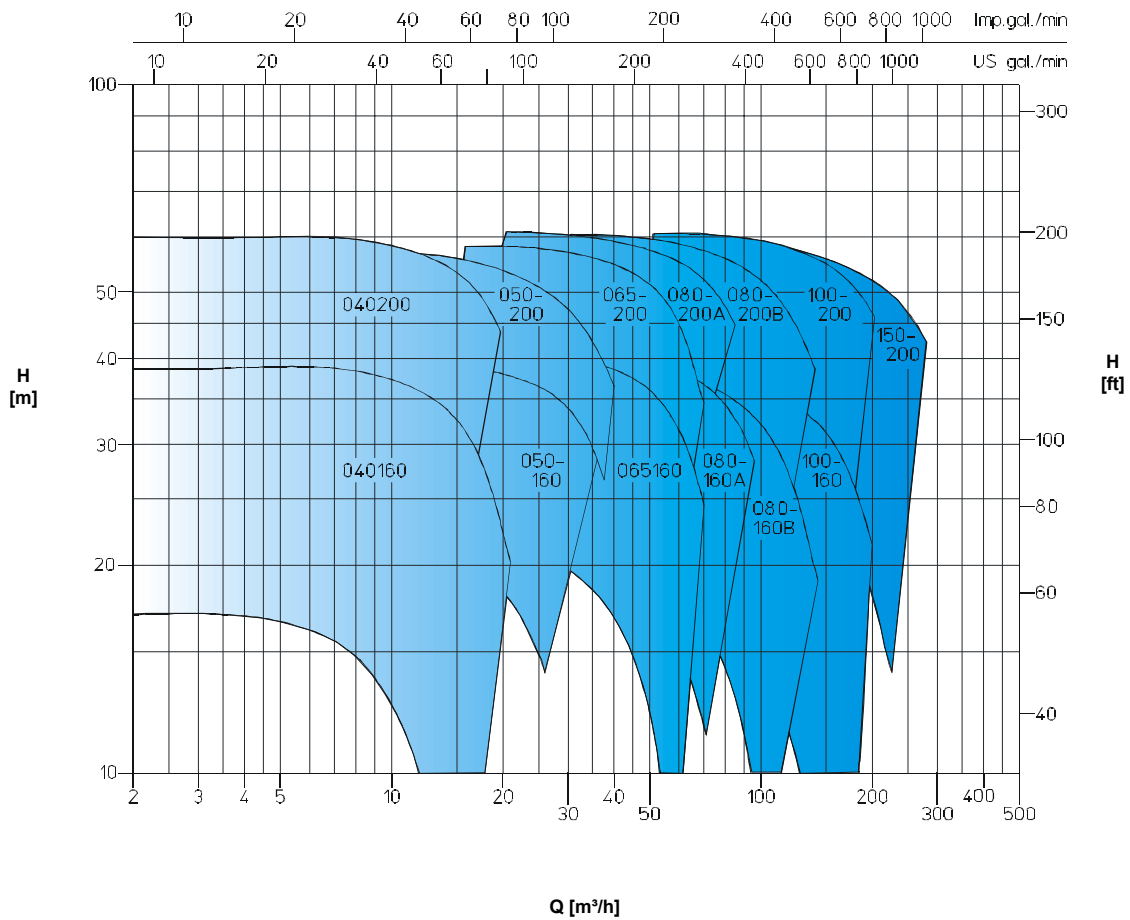

Dimension table

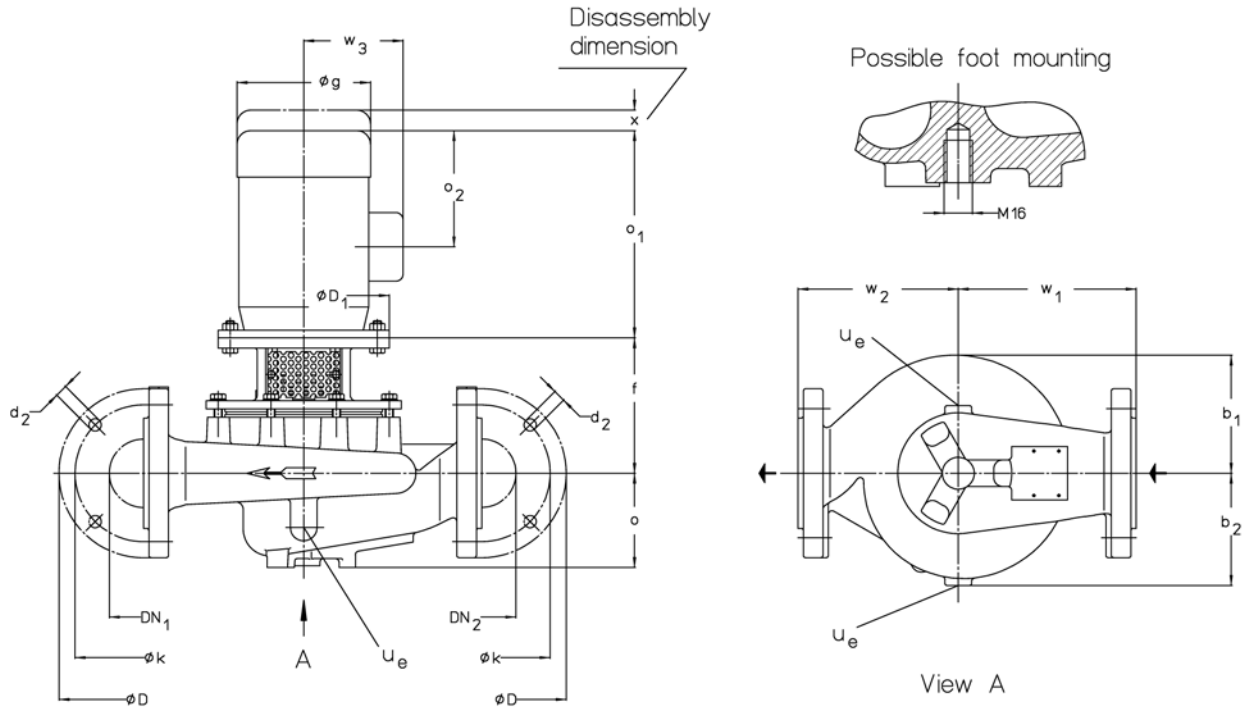

ue = connection for drainage G 3/8

n = 1450 rpm

Size	Motor		DN _{1,2}	b ₁	b ₂	D ₁	f	g*	o	o ₁ *	o ₂ *	w ₃ *	w ₁	w ₂	x	Weight abt. kg										
	Size	kW														Pump 0B,0C	Pump 4B	Motor								
040160	80	0,55	40	113	114	200	167	82	82	253	178	133	180	160	80	36	37	10								
040200	80	0,55		133	127														175	90	200	180	43	47	11	
	90 S	1,1		190	298														220	140	200	180	15			
050160	80	0,55	50	121	119	200	167	90	90	253	178	133	190	160	80	40	42	10								
050200	80	0,75		138	138														175	90	200	180	11			
	90 L	1,5		190	298														220	140	200	180	15			
065160	80	0,75	65	132	127	200	167	106	106	253	178	133	215	200	80	42	48	11								
065200	90 S	1,1		147	143														175	106	215	200	15			
	100 L	2,2		250	325														229	170	215	200	17			
080160 A	80	0,75	80	139	120	200	167	150	150	253	178	133	240	200	80	40	46	15								
080200 A	90 S	1,1		150	136														190	150	240	200	15			
	90 L	1,5		210	325														229	170	255	225	17			
080160 B	90 S	1,1	80	148	137	200	167	120	120	298	220	140	240	200	80	50	53	15								
080200 B	90 L	1,5		155	155														190	120	240	200	17			
	100 L	2,2		250	325														229	170	255	225	24			
100160	90 L	1,5	100	165	145	200	167	150	150	298	220	140	275	225	100	52	61	24								
100200	100 L	2,2		180	162														210	150	275	250	28			
	112 M	4,0		250	183														236	188	350	248	180	63	68	36
150200	132 S	5,5	150	203	173	300	226	275	188	350	248	180	350	280	120	78	84	49								
	112 M	4,0																	250	183	236	188	350	248	180	49
	132 M	7,5																	300	226	275	188	435	327	195	58

n = 2900 rpm

Size	Motor		DN _{1,2}	b ₁	b ₂	D ₁	f	g*	o	o ₁ *	o ₂ *	w ₃ *	w ₁	w ₂	x	Weight abt. kg						
	Size	kW														Pump 0B,0C	Pump 4B	Motor				
040160	90 L	2,2	40	113	114	200	167	190	82	298	220	140	180	160	80	36	37	18				
	100 L	3,0				250	162	210										325	229	170	24	
	112 M	4,0				236	236	350										248	180	41		
040200	112 M	4,0	133	127	300	210	275	275	90	325	229	170	200	180	43	47	56					
	132 S	5,5															435	327	195	59		
050160	100 L	3,0	50	121	119	250	162	210	106	325	229	170	190	160	40	42	24					
	112 M	4,0				236	236	350									248	180	41			
050200	132 S	5,5	138	138	300	275	275	275	90	325	229	170	200	180	44	47	56					
	132 S	7,5															435	327	195	59		
065160	100 L	3,0	65	132	127	250	162	210	106	325	229	170	200	180	42	48	24					
	112 M	4,0				236	236	350									248	180	41			
	132 S	5,5				275	275	435									327	195	56			
065200	132 S	7,5	147	143	350	275	275	275	106	325	229	170	215	200	48	52	110					
	160 M	11,0															335	335	545	400	250	110
	160 M	15,0															275	275	435	327	195	110
080160 A	132 S	5,5	80	139	120	300	210	275	150	435	327	195	240	200	40	46	56					
	132 S	7,5				335		335									545	400	250	59		
080200 A	160 M	11,0	150	136	350	350	210	335	136	545	400	250	255	225	45	49	110					
	160 M	15,0						275									275	435	327	195	110	
	160 L	18,5						335									335	545	400	250	110	
080160 B	132 S	7,5	80	148	137	300	210	275	120	435	327	195	240	200	50	53	59					
	160 M	11,0				335		335									545	400	250	110		
080200 B	160 M	15,0	165	155	400	350	210	335	120	545	400	250	255	225	51	54	110					
	160 L	18,5						380									380	600	450	275	110	
	180 M	22,0						415									415	673	488	300	110	
100160	200 L	30,0	100	165	145	350	210	335	150	545	400	250	275	100	52	61	110					
	160 M	11,0						380									380	600	450	275	110	
	160 M	15,0						415									415	673	488	300	110	
100200	160 L	18,5	180	162	400	350	226	335	150	545	400	250	275	250	63	68	110					
	180 M	22,0						380									380	600	450	275	110	
	200 L	30,0						415									415	673	488	300	110	
150200	180 M	22,0	150	203	173	400	226	380	188	600	450	275	350	280	120	78	84	155				
	200 L	30,0						415										415	673	488	300	155
	200 L	37,0																260				

Flange connections to DIN 2501 PN 16						
DN _{1,2}	40	50	65	80	100	150
k	110	125	145	160	180	240
D	150	165	185	200	220	285
d ₂ x number	18 x 4	18 x 4	18 x 4	18 x 8	18 x 8	23 x 8

Standard motors as per DIN 42677.
Truth of rotation, centricity and right angle of shaft ends and mounting flanges to DIN 42955, normal precision.

* Motors protection type IP 55
Dimensions depend on the motor make

Data regarding pump size

Type	Pump size	Hydraulic + Bearing	Shaft sealing	Material design		Casing seal	
		<ul style="list-style-type: none"> A ▪ First hydraulic B ▪ Second hydraulic ▪ K, V Two grease-lubricated antifriction bearings in the motor. One grease-lubricated antifriction bearing in the bearing bracket. 	AAE: Standard mechanical seal, O-rings Perbunan BH3: Unbalanced mechanical seal, SiC-Carbon, elastomer EPDM bellows. BHS: Unbalanced mechanical seal, SiC/SiC, elastomer Viton bellows.	0B: Main parts of cast iron GG25. 0C: Main parts of cast iron GG25, Bronze G-CuSn10 4B: Main parts of stainless steel 1.4408		2: Confined flat gasket of EWP 210. 4: Confined flat gasket of PTFE.	
			AAE, BH3, BHS	0B 2	0C 2	--	
			BH3, BHS	--	--	4B 4	
ZLIC	040160 040200 050160 050200	AV		●	●	●	
				●	●	●	
				●	●	●	
				●	●	●	
ZLIB	065160 065200			●	●	●	
				●	●	●	
				●	●	●	
				●	●	●	
ZLIC	080160 080200			BV	●	●	●
				●	●	●	
		AV	●	●	●		
		AK	●	●	●		
	100160 100200 150200		●	●	●		

Applicable motors please take from the dimension table

Motor selection table					
n = 2900 rpm			n = 1450 rpm		
kW	Size	Designation	kW	Size	Designation
0,75	80	FA	0,55	80	FB
1,1	80	GA	0,75	80	GB
1,5	90 S	HA	1,1	90 S	HB
2,2	90 L	JA	1,5	90 L	JB
3,0	100 L	KA	2,2	100 L	KB
4,0	112 M	MA	3,0	100 L	LB
5,5	132 S	NA	4,0	112 M	MB
7,5	132 S	OA	5,5	132 S	NB
11,0	160 M	SA	7,5	132 M	PB
15,0	160 M	TA	---	---	---
18,5	160 L	UA			
22,0	180 M	VA			
30,0	200 L	XA			
37,0	200 L	YA			

COPYRIGHT WARNING

Please read this notice

The material you are viewing in this document is protected by Copyright and may only be used in accordance with Copyright, Designs and Patent legislation.

It is not permitted to copy - either in full or in part - nor substantially extract, reproduce or re-use any of the contents of this document in any material form or in any medium without permission from the Copyright holders or their assignees. Any unlawful use of the material in this document may result in claims for civil remedies, including an injunction to restrain further use and a claim for damages; or may result in criminal penalties.

Sterling Fluid Systems (Spain), S.A.

Vereda de los Zapateros s/n, Pozuelo de Alarcón 28223 Madrid, Spain.
Telephone +34 91 709 1310 Telefax +34 91 715 9700. E-mail mibsa@stnet.es